

Quality engineering - Made in Germany: functional, robust and reliable

Jungheinrich drive axle and maintenance-free wet-disc brakes with electric parking brake

High visibility in all directions due to unique 'vision window' mast design

Truck design concept giving high productivity with low fuel consumption and high dynamic stability

Rugged Kubota industrial engines with high torque at low revs

4 point cushion mounted drive train giving a low-vibration operators cab area



DFG/TFG 316/320

Diesel and LPG forklifts with hydrodynamic drive (Torque Converter) (1,600/2,000 kg)

Our robust torque converter counterbalance trucks give you high productivity coupled with high reliability in all applications. The simple design of the torque converter drive train allows it to be used in a wide range of rugged and industrial operations; in addition it provides smooth power take up whilst accelerating, producing optimum efficiency at all speeds.

The rugged Kubota engines have been tried and tested throughout the world in harsh environments, including high and low temperatures, high humidity and tough terrains, returning optimum reliability.

Giving the strong benefit of lower fuel consumption and minimal noise. These robust engines are specifically designed for use in fork lift trucks. Giving you outstanding reliability and a long service life.

High levels of efficiency are delivered through the Jungheinrich

drive axle with integrated, maintenance free wet-disc brakes. Eliminating unnecessary costs associated with brake wear and lowering overall lifetime costs. The enclosed design of the braking system helps protect it by eliminating ingress of water or dust, which is typical in harsh conditions.

The operators cab is designed with the operator in mind. The visibility in all directions is class leading enhancing all round safety, resulting in a safe and productive driver maximising throughput throughout the shift.

Due to the unique Jungheinrich counterweight design, the centre of gravity is both low and centred between both front and rear the axles. This results in best in class dynamic stability and driving safety without unnecessary external electronic stability systems.

DFG/TFG 316/320

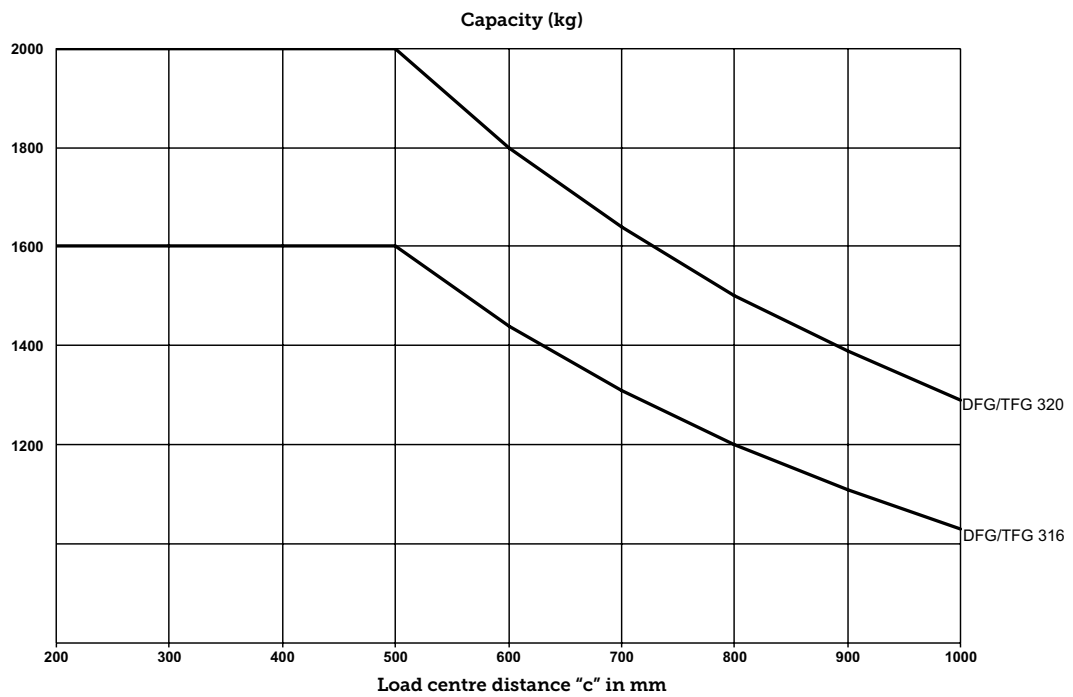
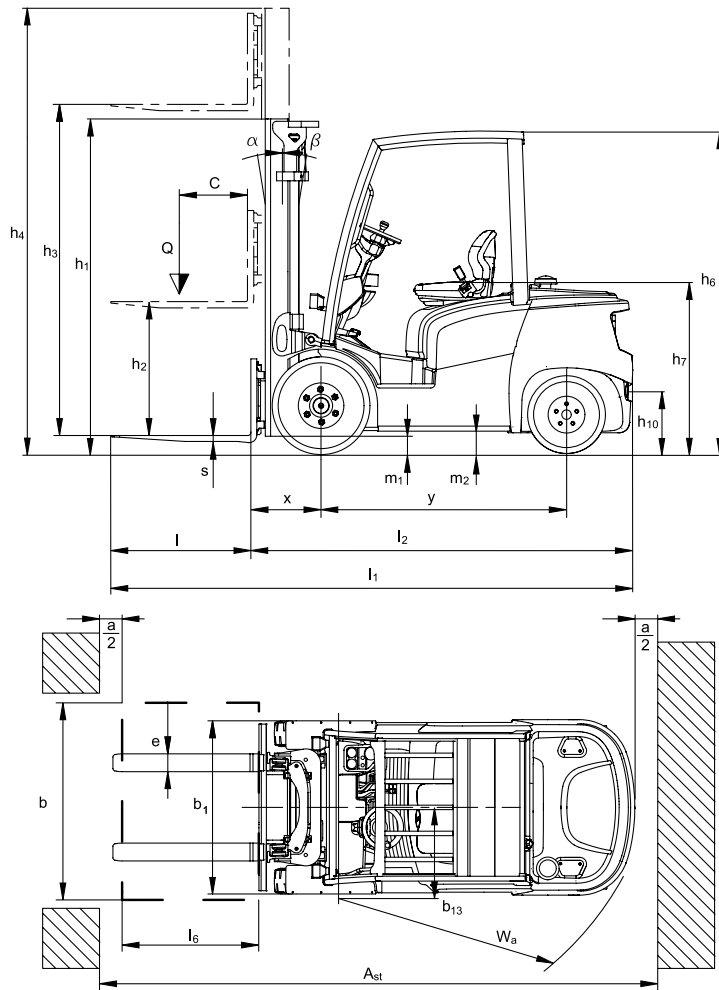

DFG/TFG 316/320

Standard mast types DFG 316/DFG 320/TFG 316/TFG 320								
	Lift h_3 (mm)	Lowered mast height h_1 (mm)		Free lift h_2 (mm)		Extended mast height h_4 (mm)		Mast tilt forward / back α/β (°)
		DFG 316 / TFG 316	DFG 320 / TFG 320	DFG 316 / TFG 316	DFG 320 / TFG 320	DFG 316 / TFG 316	DFG 320 / TFG 320	
		Duplex ZT	2900	2016	2023	150	150	
	3100	2116	2123	150	150	3690	3712	6/7
	3300	2216	2223	150	150	3890	3912	6/7
	3500	2316	2323	150	150	4090	4112	6/5
	3700	2416	2423	150	150	4290	4312	6/5
	4000	2516	2523	150	150	4590	4612	6/5
	4300	2716	2723	150	150	4890	4912	6/5
	4500	2816	2823	150	150	5090	5112	6/5
Duplex ZZ	3100	2071	2078	1481	1436	3690	3742	6/7
	3300	2171	2178	1581	1536	3890	3942	6/7
	3500	2271	2278	1681	1636	4090	4142	6/5
	3700	2371	2378	1781	1736	4290	4342	6/5
	4000	2521	2528	1931	1886	4590	4642	6/5
Triplex DZ	4400	2031	2038	1441	1396	4990	5042	6/5
	4640	2111	2118	1521	1476	5230	5282	6/5
	4700	2131	2138	1541	1496	5290	5342	6/5
	4800	2171	2178	1581	1536	5390	5442	6/5
	5000	2241	2248	1651	1606	5590	5642	6/5
	5500	2421	2428	1831	1786	6090	6142	6/5
	6000	2591	2598	2001	1951	6590	6642	6/5
	6500	2771	2778	2181	2136	7090	7142	6/5
	7000	2941	2948	2351	2306	7590	7642	6/5
	7500	3111	3118	2521	2476	8090	8142	6/5

Technical data in line with VDI 2198

			Jungheinrich	
			DFG 316	DFG 320
Identification	1.1	Manufacturer (short form)	Jungheinrich	
	1.2	Model	DFG 316	DFG 320
	1.3	Drive	Diesel	
	1.4	Manual, pedestrian, stand-on, seated, order picker operation	seat	
	1.5	Load capacity/rated load	1.6	2
	1.6	Load centre distance	500	
	1.8	Load distance	409 ¹⁾	416 ¹⁾
	1.9	Wheelbase	1,500	
	Weights	2.1	Service weight	2,620
2.2		Axle load, w. load, front / rear	3,780 / 440	4,440 / 540
2.3		Axle load, w.o. load, front / rear	1,210 / 1,410	1,220 / 1,760
Wheels / chassis	3.1	Tyres	Pneumatic	
	3.2	Tyre size, at front	6.50-10	
	3.3	Tyre size, at rear	18x7-8	
	3.5	Wheels, number front/rear (x = driven wheels)	2x/2	
	3.6	Track width, front	b ₁₀ mm	921
	3.7	Track width, rear	b ₁₁ mm	870
	Basic dimensions	4.1	Tilt of mast/fork carriage forward/backward	α/β °
4.2		Mast height (lowered)	2,016	2,023
4.3		Free lift	150	
4.4		Lift	2,900	
4.5		Extended mast height	3,490	3,512
4.7		Height of overhead guard	2,120	
4.8		Seat height/stand height	1,075	
4.12		Coupling height	375	372
4.19		Overall length	3,311	3,368
4.20		Length incl. back of forks	2,261	2,318
4.21		Total width	b ₁ /b ₂ mm	
4.22		Fork dimensions	s/e/l mm	
4.23		Fork carriage ISO 2328, class/type A, B	40 / 100 / 1,050	
4.24		Fork carriage width	2A	
4.31		Floor clearance with load under mast	b ₃ mm	980
4.32		Floor clearance centre wheelbase	m ₁ mm	93
4.33		Aisle width for pallets 1000 x 1200 sideways	m ₂ mm	111
4.34		Aisle width for pallets 800 x 1200 lengthways	Ast mm	3,630
4.35	Turning radius	Ast mm	3,829	
4.36	Smallest pivot point distance	W _a mm	2,020	
Performance data	5.1	Travel speed, w. / w.o. load	b ₁₃ mm	
	5.2	Lift speed, w. / w.o. load	562	
	5.3	Lower speed, w. / w.o. load	18 / 19	
	5.5	Drawbar pull w. / w.o. load	0.54 / 0.58	0.57 / 0.59
	5.7	Gradeability laden/unladen	0.55 / 0.55	
	5.9.2	Acceleration laden/unladen to 15 m	14,000	
	5.10	Service brake	27 / 30	22 / 30
Combustion engine	5.11	Parking brake	5.2 / 4.5	
	7.1	Engine manufacturer / type	hydraulic	
	7.2	Engine output according to ISO 1585	hydraulic	
	7.3	Rated revolutions per minute	Kubota V2403-M	
	7.4	No. of cylinders	31.2	
	7.4.1	Cubic capacity	2,200	
	7.5	Fuel consumption acc. to VDI cycle	4	
Misc.	8.1	Type of drive control	2,434	
	8.2	Working pressure for attachments	2.4	2.8
	8.3	Oil flow for attachments	hydrodynamic	
	8.4	Sound pressure level at operator's ear according to EN 12053	210	
	8.5	Trailer coupling, model/type DIN	40	
	8.6	Steering	82	

¹⁾ Integrated Sideshifter +27,5 mm

Technical data in line with VDI 2198

			Jungheinrich	
			TFG 316	TFG 320
Identification	1.1	Manufacturer (short form)	Jungheinrich	
	1.2	Model	TFG 316	TFG 320
	1.3	Drive	LPG	
	1.4	Manual, pedestrian, stand-on, seated, order picker operation	seat	
	1.5	Load capacity/rated load	Q	t
	1.6	Load centre distance	c	mm
	1.8	Load distance	x	mm
	1.9	Wheelbase	y	mm
				1,6
			500	
			409 ¹⁾	416 ¹⁾
			1,500	
Weights	2.1	Service weight	kg	
	2.2	Axle load, w. load, front / rear	kg	
	2.3	Axle load, w.o. load, front / rear	kg	
			2,620	2,980
			3,760 / 460	4,420 / 560
			1,190 / 1,430	1,200 / 1,780
Wheels / chassis	3.1	Tyres	Pneumatic	
	3.2	Tyre size, at front	mm	
	3.3	Tyre size, at rear	mm	
	3.5	Wheels, number front/rear (x = driven wheels)		
	3.6	Track width, front	b ₁₀	mm
	3.7	Track width, rear	b ₁₁	mm
				921
			6/7	
Basic dimensions	4.1	Tilt of mast/fork carriage forward/backward	α/β °	
	4.2	Mast height (lowered)	h ₁	mm
	4.3	Free lift	h ₂	mm
	4.4	Lift	h ₃	mm
	4.5	Extended mast height	h ₄	mm
	4.7	Height of overhead guard	h ₆	mm
	4.8	Seat height/stand height	h ₇	mm
	4.12	Coupling height	h ₁₀	mm
	4.19	Overall length	l ₁	mm
	4.20	Length incl. back of forks	l ₂	mm
	4.21	Total width	b ₁ /b ₂	mm
	4.22	Fork dimensions	s/e/l	mm
	4.23	Fork carriage ISO 2328, class/type A, B		
	4.24	Fork carriage width	b ₃	mm
	4.31	Floor clearance with load under mast	m ₁	mm
	4.32	Floor clearance centre wheelbase	m ₂	mm
	4.33	Aisle width for pallets 1000 x 1200 sideways	Ast	mm
4.34	Aisle width for pallets 800 x 1200 lengthways	Ast	mm	
4.35	Turning radius	W _a	mm	
4.36	Smallest pivot point distance	b ₁₃	mm	
			2,016	2,023
			150	
			2,900	
			3,490	3,512
			2,120	
			1,075	
			375	372
			3,311	3,368
			2,261	2,318
			1,113	
			40 / 100 / 1,050	
			2A	
			980	
			93	95
			111	109
			3,630	3,667
			3,829	3,866
			2,020	2,050
			562	
Performance data	5.1	Travel speed, w. / w.o. load	km/h	
	5.2	Lift speed, w. / w.o. load	m/s	
	5.3	Lower speed, w. / w.o. load	m/s	
	5.5	Drawbar pull w. / w.o. load	N	
	5.7	Gradeability laden/unladen	%	
	5.9.2	Acceleration laden/unladen to 15 m	S	
	5.10	Service brake		
5.11	Parking brake			
			19 / 20	
			0.56 / 0.58	0.58 / 0.6
			0.55 / 0.55	
			14,000	
			27 / 30	25 / 30
			4.7 / 4	4.9 / 4.2
			hydraulic	hydraulic
			hydraulic	hydraulic
Combustion engine	7.1	Engine manufacturer / type	Kubota WG2503-L	
	7.2	Engine output according to ISO 1585	kW	
	7.3	Rated revolutions per minute	/min	
	7.4	No. of cylinders		
	7.4.1	Cubic capacity	cm ³	
	7.5.1	Fuel consumption acc. to VDI cycle	kg/h	
			30	
			2,200	
			4	
			2,491	
			2.8	2.9
Misc.	8.1	Type of drive control	hydrodynamic	
	8.2	Working pressure for attachments	bar	
	8.3	Oil flow for attachments	l/min	
	8.4	Sound pressure level at operator's ear according to EN 12053	dB (A)	
	8.5	Trailer coupling, model/type DIN		
	8.6	Steering		
			210	
			40	
			82	
			Bolt	
			hydraulic	

¹⁾ Integrated Sideshifter +27,5 mm

DFG/TFG 316/320



Standard delivery specification

- Operators cab entry handle on upright of overhead load guard. High visibility overhead load guard suitable, as standard, for containers.
- Hydraulic steering on demand with load sensing technology.
- Steering column with adjustable tilt.
- Travel direction lever mounted on steering column.
- Individual hydraulic levers on the operators dashboard.
- Instrumentation with glare-free display for hour meter and tank capacity. Indicator lights for: - engine oil pressure, coolant temperature, battery charge, parking brake, transmission oil temperature, brake fluid level, neutral display, low fuel level warning (diesel), electronic preheating (diesel) and water in the diesel filter.
- Acoustic warning for excess coolant temperature.
- MSG20 faux leather seat with automatic lap belt and mechanical suspension. Setting options: Fore and aft adjustment, backrest tilt and weight adjustment (up to 130 kg).
- Functional storage compartments suitable for everyday use including a drink holder.
- Anti-noise and vibration rubber floor mat.
- Standard automotive pedal layout.
- Wet maintenance-free disc brakes with electric parking brake and audible safety warning.
- Two front halogen spotlights and two brake/rear lights on rear counterweight.
- Hydraulic control valve incorporating load sensing technology.
- Full-flow hydraulic oil filtration with suction and return filtering for maximum oil purity.
- Heavy duty cyclonic air cleaner.
- Oil cooler for torque converter and transmission oil.
- Closed pressurised cooling system.
- Enclosed towbar on counterweight.
- Full length belly plate.

Benefit from the advantages



Entry via a deep, wide step. Large, strong grab handle welded to the overhead guard.

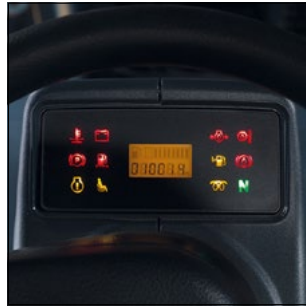

Display in the operator's field of vision.



Automotive pedal configuration with non-slip surface.



Optimum view of the load thanks to lift mast design giving ideal visibility.

Powerful and efficient drive concept

- Tried and tested in harsh construction environments, industrial engines from Kubota in diesel and LPG models.
- Sturdy and modern engines. Designed for durability, high load capacity and reliability.
- High torque at low engine revs.
- Engine timing via inclined spurtoothed wheels.
- Engines with low emissions (diesel engines as per Directive 97/68/ EU stage 3A).

Ergonomic operator workstation

- The visibility in all directions is class leading enhancing all round safety.
- Entry via a deep, wide step. The step is clearly visible from the seated position.
- Large, strong grab handle welded to the overhead guard.
- Generous knee and legroom thanks to slim and easily adjustable steering column.
- Ergonomic steering wheel offset to the left.
- Effortless operation with hydraulic power assisted steering.
- Large, level footwell with vibration absorbing floor mat.
- Sturdy hydraulic levers positioned for easy use even when wearing gloves.
- Comfortable operators seat with excellent suspension and numerous adjustment options.
- Displays and switches for additional equipment (e.g. lighting and wipers) are positioned within the operator's reach and field of vision.
- Numerous storage options, such as drink holder, documents clip and a compartment for every day objects.
- Electrically applied parking brake, easily operated at the push of a button. Eliminating the usual knock on/knock off lever which restricts access in the knee and entry area.
- Automotive pedal layout with non-slip anti vibration surface.

Mast and hydraulics

- Smooth transitions provided by the mast cushioning system.
- High residual capacity at high lift heights.
- High visibility due to unique vision window.

- Flush face mast channels reducing the lost load centre.
- Hydraulic hoses routed for optimum visibility.
- Vision windows in the free lift cylinder cross-member, make it safer to work at higher racking levels.
- Hydraulic control valve incorporating load sensing technology. Due to the lower pressure level, the load sensing system reduces the energy consumption whilst keeping the unnecessary pumping losses to a minimum.

Jungheinrich drive axle with maintenance-free wet-disc brakes

- Axle concept with optimised efficiency for low fuel consumption.
- The oil immersed wet-disc braking system is maintenance-free. There are virtually no service costs (in comparison with conventional drum braking systems).
- No negative effect on braking due to environmental influences or service related downtime due to the enclosed design.

Uncoupled power train

Improved operator comfort and reduction of unnecessary vibrations. These are kept to a minimum with:

- Floating drive unit.
- Independently mounted axle and drive train via heavy duty coupling.

Enclosed high-performance cooling system with combi cooler

- Heavy duty combi cooler in full aluminium design for engine coolant, converter and transmission oil – without the common plastic manifold which are susceptible to faults.
- Easy to clean with radiator cores of the cooling elements for engine coolant, converter and transmission oil.
- No coolant evaporation due to completely enclosed pressurised system.
- Reliable operation without a reduction in performance even at extreme ambient temperatures.

Easy to maintain and repair

- Optimum access to engine compartment due to 90° opening and L-shaped cover.

- Side sections and floor plate easily detachable without the need for tools.
- Minimal truck downtime thanks to simple, rapid and cost-effective maintenance – expert knowledge not required.
- Use of sturdy, high-quality components.
- No truck-specific diagnostic tools or special software required.
- Large fuel filter with water separator.
- Oil change interval 500 hours.

Reliable, heavy-duty electrical equipment

- Splash-proof electrics, plug and connections.
- Easily accessible at all times, compact fuse box on the operators console in the drivers compartment.

Jungheinrich high-mounted fully floating axle for high degree of passive safety

Even during dynamic travel, outstanding driving stability through reduced pendulum motion is guaranteed by the high pivot point of the steering axle. The risk of tip over is minimised by applying basic physics. Without the additional use of electronic assistance systems.

Optimised counterweight design

- The counterweight design displaces the centre of gravity downwards and forwards.
- The truck's centre of gravity is low and is situated between the front and rear axles.

Additional comfort equipment in different models (optional)

- Windscreen and rear window made of single-pane safety glass.
- Overhead roof panel made of laminated safety glass.
- Heated rear window (with vertical sliding window).
- Wipers and washer system for windscreen and rear window.
- Steel doors with sliding windows.
- Heating including windscreen demisters.
- Panoramic interior mirror.
- Left and right rear view mirrors.
- Armrest.

Benefit from the advantages



Simple, fast and affordable maintenance.



Side sections are easily detachable without tools.



Electrically applied parking brake, easily operated at the push of a button.



Heating including air demister for windscreen.

- Comfort seats in fabric or synthetic leather.

Benefit from our safety and environmental benefits:

- Automatic hydraulic and travel interlock when the operator leaves the seat. All hydraulic functions and travel are only possible when the seat is occupied.
- Acoustic warning when the operator's seat is vacated, if the parking brake is not applied.
- Transmission is automatically placed into neutral as soon as operator leaves the truck.
- All diesel engines comply with the EU exhaust emissions stage 3A regulations.

Jungheinrich
Vertrieb Deutschland AG & Co. KG

Am Stadtrand 35
D-22047 Hamburg
Telephone +49 40 6948-0
Telefax +49 40 6948-1777

info@jungheinrich.com
www.jungheinrich.com

The German production facilities in Norderstedt and Moosburg are certified. **ISO 9001**
ISO 14001

Jungheinrich fork lift trucks meet European safety requirements.



JUNGHEINRICH
Machines. Ideas. Solutions.