

High performance trucks with low energy consumption

Electric hydraulic steering for improved operator comfort

Safe sideways battery removal with SnapFit

Quickly and intuitively adaptable operating cab

Operator assistance systems to suit any application

Compact mast for best visibility



## **EFG 213/215/216k/216/218k/218/220**

**Electric three-wheel counterbalance truck with twin-coupled rear wheels (1,300/1,500/1,600/1,800/2,000 kg)**

Our Series 2 electric fork lift trucks with capacities up to 2000 kg are the cost-effective solution for all applications where maximum manoeuvrability is required on level surfaces in cramped conditions. Thanks to our Pure Energy technology concept, the three-wheel trucks with a twin wheel and 5th wheel steering for 180° rotation on the spot achieve the best possible energy and cost efficiency coupled with maximum performance.

Consumption is significantly reduced by using the most advanced 3-phase AC technology as well as the compact hydraulic unit – while throughput is simultaneously increased. This is verified by VDI cycle tests: At maximum throughput, our new EFG Series 2 consumes up to 15% less energy than comparable competitor models.

Application-oriented work programs with variable travel/lift speeds will handle all of your transport and stacking operations with optimum energy efficiency. The infinitely adjustable

steering column and armrest as well as the single-point adjustment via two adjustable axes facilitate the individual adjustment of the operator position as well as the controls.

Changing the battery is as simple as refuelling: Three different battery changing options make this easy for any user – even during three-shift operations. In addition, the new compact mast noticeably expands the operator's field of vision, offering the best visibility available on the market. Important features contributing to the enhanced visibility include compact profile nesting and an optimised chain and hose guide as well as two viewing windows in the cross member.

Thanks to their robust design and future-oriented technology, our Series 2 EFG offer the best prerequisites for cost-effective applications both indoors and outdoors.

# EFG 213/215/216k/216/218k/218/220

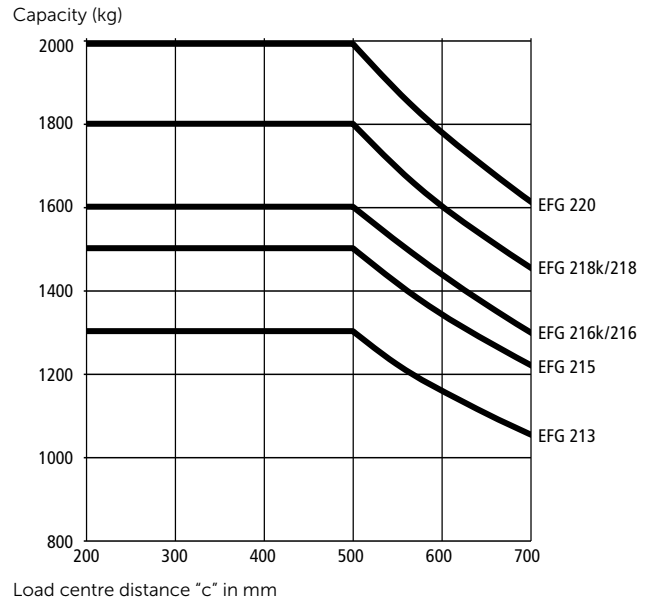
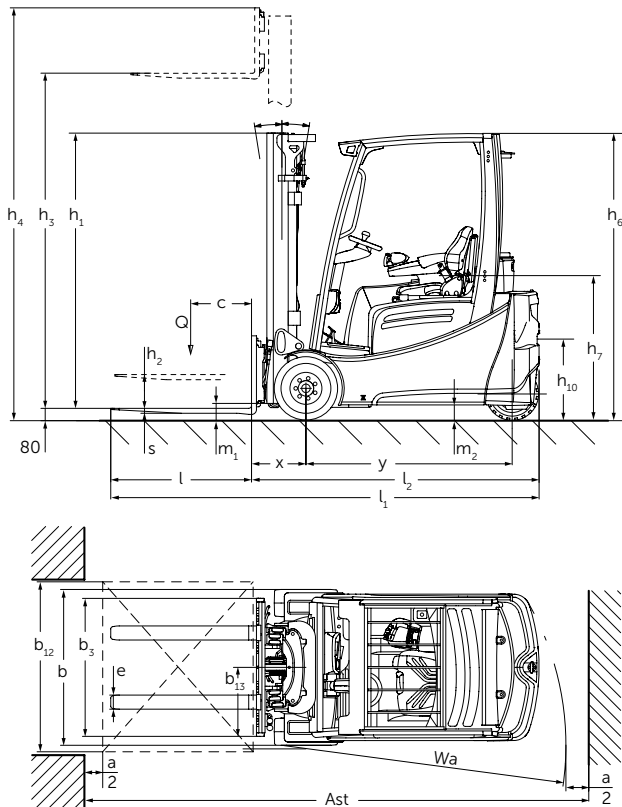

Standard mast designs EFG 213/215/216k/216/218k/218/220							Capacity chart (kg)							
	Lift $h_3$  (mm)	Lowered mast height $h_1$  (mm)	Free lift $h_2$  (mm)		Extended mast height $h_4$  (mm)		Mast tilt forward / back $\alpha/\beta$ (°)	c=500  no side-shift, tyres are simply solid						
			EFG 213 / 215 / 216k / 216	EFG 218k / 218 / 220	EFG 213 / 215 / 216k / 216	EFG 218k / 218 / 220		EFG 213 / 215 / 216k / 216	EFG 218k / 218 / 220	EFG 213	EFG 215	EFG 216k / 216	EFG 218k / 218	EFG 220
			Duplex ZT	3000	2060	2067		150	150	3590	3612	7/6	1300	1500
	3100	2110	2117	150	150	3690	3712	7/6	1300	1500	1600	1800	2000	
	3300	2210	2217	150	150	3890	3912	7/7	1300	1500	1600	1800	2000	
	3500	2310	2317	150	150	4090	4112	7/7	1300	1500	1600	1800	2000	
	3700	2410	2417	150	150	4290	4312	7/7	1300	1500	1600	1800	2000	
	4000	2560	2567	150	150	4590	4612	7/7	1300	1500	1600	1800	2000	
	4500	2810	2817	150	150	5090	5112	7/7	1300	1500	1600	1800	2000	
Duplex ZZ	2900	1965	1972	1375	1330	3490	3542	7/6	1300	1500	1600	1800	2000	
	3100	2065	2072	1475	1430	3690	3742	7/6	1300	1500	1600	1800	2000	
	3180	2105	2112	1515	1470	3770	3822	7/6	1300	1500	1600	1800	2000	
	3300	2165	2172	1575	1530	3890	3942	7/7	1300	1500	1600	1800	2000	
	3500	2265	2272	1675	1630	4090	4142	7/7	1300	1500	1600	1800	2000	
	3700	2365	2372	1775	1730	4290	4342	7/7	1300	1500	1600	1800	2000	
	4000	2515	2522	1925	1880	4590	4642	7/7	1300	1500	1600	1800	2000	
Triplex DZ	4250	1975	1982	1385	1340	4840	4892	7/6	1300	1500	1600	1800	2000	
	4400	2025	2032	1435	1390	4990	5042	7/6	1300	1500	1600	1800	2000	
	4640	2105	2112	1515	1470	5230	5282	7/5	1300	1500	1600	1800	2000	
	4700	2125	2132	1535	1490	5290	5342	7/5	1300	1500	1600	1800	2000	
	4800	2165	2172	1575	1530	5390	5442	7/5	1300	1500	1600	1800	2000	
	5000	2235	2242	1645	1600	5590	5642	7/5	1300	1500	1600	1800	2000	
	5500	2415	2422	1825	1780	6090	6142	7/5	1050	1350	1350	1500	1600	
	6000	2585	2592	1995	1950	6590	6642	7/5	900	1250	1150	1300	1400	
	6500	2765	2772	2175	2130	7090	7142	7/5	750	0	950	1100	1150	

# Technical data in line with VDI 2198

		Jungheinrich									
		EFG 213	EFG 215	EFG 216k	EFG 216	EFG 218k	EFG 218	EFG 220			
Identification	1.1	Manufacturer (abbreviation)									
	1.2	Model									
	1.3	Drive	Electric								
	1.4	Manual, pedestrian, stand-on, seated, order picker operation	seat								
	1.5	Load capacity/rated load	Q	t	1.3	1.5	1.6	1.6	1.8	1.8	2
	1.6	Load centre distance	c	mm	500						
	1.8	Load distance	x	mm	339	339	344	344	364	364	364
	1.9	Wheelbase	y	mm	1,249	1,249	1,357	1,465	1,357	1,465	1,465
	Weights	2.1.1	Net weight incl. battery (see row 6.5)	kg		2,692	2,937	2,959	3,018	3,240	3,191
2.2		Axle load with load front/rear	kg		3,534 / 458	3,860 / 577	4,043 / 516	4,050 / 566	4,457 / 583	4,477 / 514	4,784 / 582
2.3		Axle load without load front/rear	kg		1,307 / 1,385	1,290 / 1,647	1,392 / 1,567	1,479 / 1,539	1,423 / 1,817	1,534 / 1,657	1,514 / 1,852
Wheels / frame	3.1	Tyres			SE(L) / SE(L)	SE(L) / SE(L)	SE(L) / SE(L)	SE(L) / SE(L)	SE / SE	SE / SE	SE / SE
	3.2	Tyre size, front	mm		18 x 7-8	18 x 7-8	18 x 7-8	18 x 7-8	200 / 50-10	200 / 50-10	200 / 50-10
	3.3	Tyre size, rear	mm		140 / 55-9						
	3.5	Wheels, number front/rear (x = driven wheels)			2x/2						
	3.6	Tread width, front	b <sub>10</sub>	mm	904	904	904	904	914	914	914
	3.7	Tread width, rear	b <sub>11</sub>	mm	176						
	Basic dimensions	4.1	Tilt of mast/fork carriage forward/backward	$\alpha/\beta$		°					
4.2		Mast height (lowered)	h <sub>1</sub>		mm	2,060	2,060	2,060	2,060	2,067	2,067
4.3		Free lift	h <sub>2</sub>		mm	150					
4.4		Lift	h <sub>3</sub>		mm	3,000					
4.5		Extended mast height	h <sub>4</sub>		mm	3,590	3,590	3,590	3,590	3,612	3,612
4.7		Height of overhead guard	h <sub>5</sub>		mm	2,040					
4.8		Seat height/stand height	h <sub>7</sub>		mm	920					
4.12		Coupling height	h <sub>10</sub>		mm	560					
4.19		Overall length	l <sub>1</sub>		mm	2,924	2,924	3,037	3,145	3,037	3,145
4.20		Length to face of forks	l <sub>2</sub>		mm	1,774	1,774	1,887	1,995	1,887	1,995
4.21		Overall width	b <sub>1</sub> /b <sub>2</sub>		mm	1,060	1,060	1,060	1,060	1,120	1,120
4.22		Fork dimensions	s/e/l		mm	35 / 100 / 1,150	35 / 100 / 1,150	40 / 100 / 1,150	40 / 100 / 1,150	40 / 100 / 1,150	40 / 100 / 1,150
4.23		Fork carriage ISO 2328, class/type A, B			2A						
4.24		Fork carriage width	b <sub>3</sub>		mm	980					
4.31		Floor clearance with load under mast	m <sub>1</sub>		mm	97	97	97	97	105	105
4.32		Ground clearance, centre of wheelbase	m <sub>2</sub>		mm	100					
4.33		Aisle width for pallets 1000 x 1200 sideways	Ast		mm	3,104	3,104	3,216	3,323	3,216	3,323
4.34	Aisle width for pallets 800 x 1200 lengthways	Ast		mm	3,226	3,226	3,339	3,446	3,339	3,446	
4.35	Turning radius	W <sub>0</sub>		mm	1,440	1,440	1,548	1,655	1,548	1,655	
4.36	Smallest pivot point distance	b <sub>13</sub>		mm	0						
Performance data	5.1	Travel speed, laden/unladen	km/h		16 / 16						
	5.2	Lift speed, laden/unladen	m/s		0.48 / 0.6	0.46 / 0.6	0.49 / 0.6	0.49 / 0.6	0.44 / 0.55	0.44 / 0.55	0.4 / 0.55
	5.3	Lowering speed, laden/unladen	m/s		0.55 / 0.55						
	5.5	Drawbar pull w. / w.o. load	N		2,300 / 2,500	2,200 / 2,450	2,150 / 2,450	2,100 / 2,450	2,000 / 2,300	2,000 / 2,300	1,900 / 2,300
	5.6	Max. drawbar pull, laden/unladen	N		12,700 / 12,700	12,700 / 12,700	12,700 / 12,700	12,700 / 12,700	12,400 / 12,200	12,400 / 12,200	12,300 / 12,000
	5.7	Gradeability laden/unladen	%		12 / 20						
	5.8	Max. gradeability, laden/unladen	%		28 / 35	27 / 35	27 / 35	27 / 35	26 / 35	25 / 35	24 / 35
	5.9	Acceleration time w. / w.o. load	S		3.6 / 3.2	3.8 / 3.4	3.8 / 3.4	3.8 / 3.4	3.9 / 3.5	3.9 / 3.5	4 / 3.5
	5.10	Service brake			electric/mechanical						
	Electrics	6.1	Drive motor, output S2 60 min.	kW		4.5 / 4.5					
6.2		Lift motor, output at S3 15%	kW		11.5						
6.3		Battery as per DIN 43531 / 35/36 A, B, C, no			A 43531						
6.4		Battery voltage/nominal capacity K5	V/Ah		48 / 500	48 / 500	48 / 625	48 / 750	48 / 625	48 / 750	48 / 750
6.5		Battery weight	kg		715	715	855	1,025	855	1,025	1,025
		Battery dimensions L/W/H	mm		830 / 522 / 627	830 / 522 / 627	830 / 630 / 627	830 / 738 / 627	830 / 630 / 627	830 / 738 / 627	830 / 738 / 627
6.6		Energy consumption according to VDI cycle	kWh/h		4.2 <sup>1)</sup>	4.3 <sup>1)</sup>	4.3 <sup>1)</sup>	4.4 <sup>1)</sup>	4.7 <sup>1)</sup>	4.7 <sup>1)</sup>	4.9 <sup>1)</sup>
6.7		Throughput	t/h		104	120	128	128	138	138	146
6.8	Energy consumption at max. throughput	kWh/h		4.7	4.8	4.9	4.9	5	5	5.5	
Misc.	8.1	Type of drive control			Impuls/AC						
	8.2	Working pressure for attachments	bar		200						
	8.3	Oil flow for attachments	l/min		25						
	8.4	Sound pressure level at operator's ear as per EN 12053	dB (A)		66						
	8.5	Trailer coupling, model/type DIN			DIN 15170/H						

<sup>1)</sup> 60 VDI work cycles/h, tolerances +/- 10 % possible

# Benefit from the advantages



Professional battery management



duoPILOT



soloPILOT



multiPILOT

## Pure Energy

Our Pure Energy technology concept enables us to achieve the best possible energy efficiency coupled with maximum performance:

- Most advanced three-phase AC technology.
- Compact electronic controller.
- Compact hydraulic unit.
- Application-oriented control of the hydraulics/motors.

## Comfortable workstation

The ergonomically designed operator's cab allows for relaxed operation with low fatigue, even during long shifts:

- Light and effortless electric steering due to reduced steering effort, fewer turns of the steering wheel and a smaller steering wheel.
- Reduced steering noise and more leg-room due to elimination of hydraulic components in the foot-well.
- Height/tilt-adjustable steering column.
- Particularly comfortable operation thanks to integration of all main controls into the armrest which moves with the operator.
- Limited vibration as the cab is not directly connected to the chassis (Floating Cab).
- Clear visibility of the load thanks to an optimised chain as well as hose layout.
- Compact nested profile package with excellent visibility.

- High-resolution, contrast-rich full colour TFT display with self-explanatory symbols.
- USB port for external power supply (optional).

## Ergonomic and easily adjustable operating concept

- A choice of five parametrised travel programs.
- Stepless single-point adjustment of the armrest and steering column in two axes.
- Adjustable lever and axis assignment of the controls.
- Single or double pedal operation.
- Activation of the truck by EasyAccess via softkey, PIN code or transponder card (optional).

## Professional battery management

Lateral battery access:

- Various battery changing options using pedestrian pallet trucks, fork lifts or cranes.
- Simple, space-saving charging via side door.
- Easy access for maintenance.
- Safe operation.

## Maintenance-free braking system

Three maintenance-free braking systems make braking safe and comfortable:

- Motor brake for wear-free regenerative braking.
- Automatically engaging parking brake for secure stopping, even on ramps.

- Maintenance-free disc brake for maximum braking.

## Safety systems

Outstanding travel dynamics and performance levels also require a high level of safety.

That is why the EFG Series 2 includes a comprehensive range of safety equipment:

- Deactivation of the hydraulic functions if seat is unoccupied.
- No roll-back on ramps or inclines due to the automatic parking brake, even when the truck is switched off.
- Automatic reduction of the travel speed when cornering with Jungheinrich Curve Control.
- Speedometer.

A range of optional operator assistance systems (optional) provides additional safety for the operator, truck and load:

- Access Control: The access control system only unlocks the truck after a sequence of safety checks.
- Drive Control: The speed control which automatically reduces the speed of travel when cornering and from a defined lift height.
- Lift Control: The lift speed control which, in addition to the travel speed reduction, also automatically reduces the tilt speed of the mast from a defined lift height. The tilt angle is shown on a separate display.

## Jungheinrich Aktiengesellschaft

Friedrich-Ebert-Damm 129  
D-22047 Hamburg  
Telephone +49 40 6948-0  
Telefax +49 40 6948-1777

info@jungheinrich.com  
www.jungheinrich.com

The German production facilities in Norderstedt, Moosburg and Landsberg are certified.

ISO 9001  
ISO 14001

Jungheinrich fork lift trucks meet European safety requirements.



**JUNGHEINRICH**  
Machines. Ideas. Solutions.